

autovictor

 *Keep on moving to the future.*

MANUALE TECNICO ORMIG 804 AC



ORMIG

804 AC



TECHNICAL FEATURES

FRAME

Carrier: 8 x 4 x 4
Track: 1875x5020x1380 mm
Power take-off in the gear-box with 100 daNm capacity
Max.weight capability: 44,000 kg

UPPERFRAME

Outriggers:

one section beams controlled by oleodynamic cylinders; the bearing cylinders permit stabilization on uneven ground.

Rotation by means of oleodynamic cylinders.

The controls are located either in the superstructure cab or in the frame sides.

SUPERSTRUCTURE

Superstructure:

box-type monolithic structure fabricated from high tensile steels

Slewing:

the superstructure is connected to the frame by means of a 3-row rollers bearing, providing 360 degrees continuous rotation. Three slewing speeds from 0 to 2.03 rpm.

A foot pedal control in the cab is fitted in order to allow free rotation of the superstructure and self-alignment when the designated load is not in the vertical line of the hook, thus dangerous torsional stresses are avoided.

The locking of the superstructure on the frame is provided by means of double acting air-operated cylinder controlled by a switch in the cab.

Boom:

fabricated from steel sheets at high yielding point. 6 telescopic sections, fully retracted boom length 7.4 m. Total boom length 33.15 m. Height from the ground 36 m.

Boom extraction:

1st section at oleodynamic operation by means of double acting cylinder

2nd, 3rd, 4th and 5th section at oleodynamic extraction by means of telescopic cylinder

2nd section at independent extraction;

3rd, 4th, 5th section at simultaneous and proportional extraction

Boom lifting:

by means of an oleodynamic double acting cylinder

Cab:

wide visibility, steel structure, safety glasses.

The controls are operated by levers equipped with safety electrical device to protect system against incorrect operation. Controls can be actuated simultaneously. Outriggers positioning and carrier travel at site can be carried out from the cab upon request.

Hydraulic system:

Fed by 1 pistons pump at variable delivery and 2 gears pumps having max delivery of 408 litres/min. allowing for the simultaneous operation of all the controls.

Main winch:

oleodynamic with automatic brake.

Max speed 92 m/min, 6000 daN capacity at 4th layer

Max rope length 150 m, rope dia. 17 mm

Safe load device:

electronic active type, providing cut out of the controls which can cause dangerous conditions when the rated load is reached.

OPTIONAL EQUIPMENT:

Auxiliary winch, towing winch, towing beam, lattice flyjibs, travel control on superstructure cab, auxiliary counterweights, superstructure cab heater, electric motor in the superstructure.

Din 15019.2

TABELLA PORTATA DI SOLLEVAMENTO (TON) LIFTING CAPACITY CHART (TONNES) HUBLASTTABELLE (TONNEN) TABLE DES CAPACITÉS DE LEVAGE (TONNES)



7,40m-33,15m



7,02m x 7,40m



300°



0 t

DIN / ISO

m													m
	7,40	10,30	11,70	14,60	16,05	20,40	24,70	27,60	29,65	33,15	7,40	10,30	
3	80*	60	45	35									3
4	52	52	38	35	25	18					40		4
5		40	33	31	25	18	18				35	40	5
6		30	29	27	25	18	18	18	15			30	6
7		23	22,6	22,1	21,6	18	18	16,6	14,5	9,5		23	7
8			16,2	19,3	16,6	16,7	16,4	15,4	13,8	8,7		16,2	8
9				15	14,9	13,5	13,6	12,7	12,5	8			9
10				12,1	12	12,5	11,7	10,9	10,8	7,3			10
12					8,4	8,9	8,7	8	8	6,3			12
14						6,6	6,4	6,1	6,1	5,4			14
16							5,1	4,9	4,6	4,8	4,5		16
18								3,8	3,5	3,7	3,6		18
20								3	2,7	2,8	2,8		20
22									2,1	2,2	2,2		22
24										1,6	1,7		24
26											1,3		26
28											0,9		28
30													30
I	0	56	84	84/0	84/0	84/0	84/56	84	84	100	0	56	I
II	0	0	0	56/56	84/84	84/84	84/56	84	84	100	0	0	II
III	0	0	0	0/28	0/28	28/56	56/75	75	88	100	0	0	III
IV	0	0	0	0/28	0/28	28/56	56/75	75	88	100	0	0	IV
% V	0	0	0	0/28	0/28	28/56	56/75	75	88	100	0	0	V
funi n°	10	10	8	6	4	4	4	4	4	2	8	8	funi n°

* Con attrezzatura speciale
With special attachment
Mit Spezialausrüstung
Avec équipement spécial

Din 15019.2

TABELLA PORTATA DI SOLLEVAMENTO (TON) LIFTING CAPACITY CHART (TONNES) HUBLASTTABELLE (TONNEN) TABLE DES CAPACITÉS DE LEVAGE (TONNES)



7,40m-33,15m

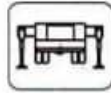

7,02m x 7,40m



300°



5.2 t

DIN / ISO

m														m
	7,40	10,30	11,70	14,60	16,05	20,40	24,70	27,60	29,65	33,15	7,40	10,30		
3	80*	60	45	35									3	
4	53,5	58	43	35	25	18					40		4	
5		45	37,3	32,3	25	18	18				35	40	5	
6		35	32,7	28,4	25	18	18	18	15			35	6	
7		27	28	25,3	23,5	18	18	16,6	14,5	9,5		27	7	
8			23,1	22,7	21	18	17	15,4	13,8	8,7		21	8	
9				20,2	18,2	17,2	15,6	14,3	13	8			9	
10				16,8	14,6	15,5	14,3	13,3	12	7,3			10	
12					11,9	11	11,6	11,5	10,5	6,3			12	
14						9,4	9,3	9	9	5,4			14	
16						7,4	7,3	7	7,1	4,7			16	
18							5,8	5,6	5,7	4,1			18	
20							4,7	4,5	4,6	3,6			20	
22								3,6	3,8	3,2			22	
24									3,1	2,8			24	
26										2,5			26	
28										2,1			28	
30													30	
	I	0	56	84	84/0	84/0	84/0	84/56	84	84	100	0	56	I
	II	0	0	0	56/56	84/84	84/84	84/56	84	84	100	0	0	II
	III	0	0	0	0/28	0/28	28/56	56/75	75	88	100	0	0	III
	IV	0	0	0	0/28	0/28	28/56	56/75	75	88	100	0	0	IV
	% V	0	0	0	0/28	0/28	28/56	56/75	75	88	100	0	0	V
funi n°	10	10	8	6	4	4	4	4	4	2	8	8	funi n°	

* Con attrezzatura speciale
With special attachment
Mit Spezialausrüstung
Avec équipement spécial

Din 15019.2

TABELLA DI PORTATA SOLLEVAMENTO JIB - 7 METRI (TON)
 FLY-JIB LIFTING CAPACITY CHART - 7 METERS (TONNES)
 HUBLASTTABELLE JIB - 7 METER (TONNEN)
 TABLE DES CAPACITÉS DE LEVAGE - FLÉCHETTE 7 MÈTRES (TONNES)



29,65m-33,15m



7,15 m

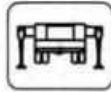

7,02m x 7,40m



300°



0 t
5,2 t

DIN / ISO

m	29,65 m						33,15 m						m	
	0 t			5,2 t			0 t			5,2 t				
	0°	20°	40°	0°	20°	40°	0°	20°	40°	0°	20°	40°		
7	6,5			6,5									7	
8	6,2	4,2		6,2	4,2		4,5			4,5			8	
9	5,8	4		5,8	4		4,2	3,5		4,2	3,5		9	
10	5,5	3,8	3	5,5	3,8	3	3,9	3,2	2,7	3,9	3,2	2,7	10	
12	5	3,5	2,9	5	3,5	2,9	3,4	2,9	2,5	3,4	2,9	2,5	12	
14	4,5	3,2	2,8	4,5	3,2	2,8	3	2,7	2,4	3	2,7	2,4	14	
16	4,1	3	2,7	4,1	3	2,7	2,7	2,5	2,3	2,7	2,5	2,3	16	
18	3,2	2,8	2,6	3,7	2,8	2,6	2,4	2,3	2,2	2,4	2,3	2,2	18	
20	2,4	2,6	2,5	3,4	2,6	2,5	2,1	2,2	2,1	2,2	2,2	2,1	20	
22	1,8	2	2,1	3,1	2,4	2,4	1,6	1,8	1,9	2	2,1	2	22	
24	1,3	1,5	1,6	2,7	2,3	2,2	1,2	1,4	1,5	1,8	2	1,9	24	
26	0,9	1	1,1	2,1	2,2	2,1	0,8	1	1,1	1,7	1,9	1,8	26	
28				1,7	1,7	1,8				1,5	1,7	1,6	28	
30				1,4	1,4	1,4				1,3	1,4	1,4	30	
32										0,9	1	1	32	
34													34	
36													36	
38													38	
funi n°	I	84						100						I
	II	84						100						II
	III	88						100						III
	IV	88						100						IV
	V	88						100						V
funi n°	2						2						funi n°	

Din 15019.2

TABELLA DI PORTATA SOLLEVAMENTO JIB - 7 + 5 METRI (TON)
 FLY-JIB LIFTING CAPACITY CHART - 7 + 5 METERS (TONNES)
 HUBLASTTABELLE JIB - 7 + 5 METER (TONNEN)
 TABLE DES CAPACITÉS DE LEVAGE - FLÉCHETTE 7 + 5 MÈTRES (TONNES)

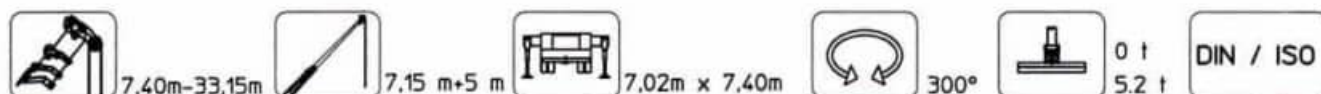

m	29,65 m						33,15 m						m
	0 t			5.2 t			0 t			5.2 t			
	0°	20°	40°	0°	20°	40°	0°	20°	40°	0°	20°	40°	
7													7
8	3			3									8
9	2,8			2,8			2,5			2,5			9
10	2,7			2,7			2,3			2,3			10
12	2,5	1,8		2,5	1,8		2,1	1,6		2,1	1,6		12
14	2,3	1,7		2,3	1,7		2	1,5		2	1,5		14
16	2,15	1,6	1,3	2,15	1,6	1,3	1,9	1,4	1,1	1,9	1,4	1,1	16
18	2	1,5	1,2	2	1,5	1,2	1,8	1,3	1,05	1,8	1,3	1,05	18
20	1,85	1,4	1,15	1,85	1,4	1,15	1,7	1,25	1	1,7	1,25	1	20
22	1,7	1,35	1,1	1,7	1,35	1,1	1,6	1,2	0,95	1,6	1,2	0,95	22
24	1,6	1,3	1,05	1,6	1,3	1,05	1,5	1,15	0,9	1,5	1,15	0,9	24
26	1,5	1,2	1	1,5	1,2	1	1,4	1,1	0,85	1,4	1,1	0,85	26
28	1,2	1,15	0,95	1,35	1,15	0,95	1,05	1,05	0,8	1,2	1,05	0,8	28
30	0,9	1,1	0,9	1,2	1,1	0,9	0,8	1		1,1	1		30
32		0,85	0,85	1,1	1	0,85		0,8		1	0,95		32
34			0,8	1	0,95	0,8				0,9	0,9		34
36													36
38													38
I II III IV % V	84						100						I II III IV % V
	84						100						
	88						100						
	88						100						
	88						100						
funi n°	2						2						funi n°

GRAFICO INCLINAZIONE BRACCIO - BOOM INCLINATION CHART
 GRAPHIK ARMNEIGUNG - DIAGRAMME DE L'INCLINASON DE LA FLÈCHE

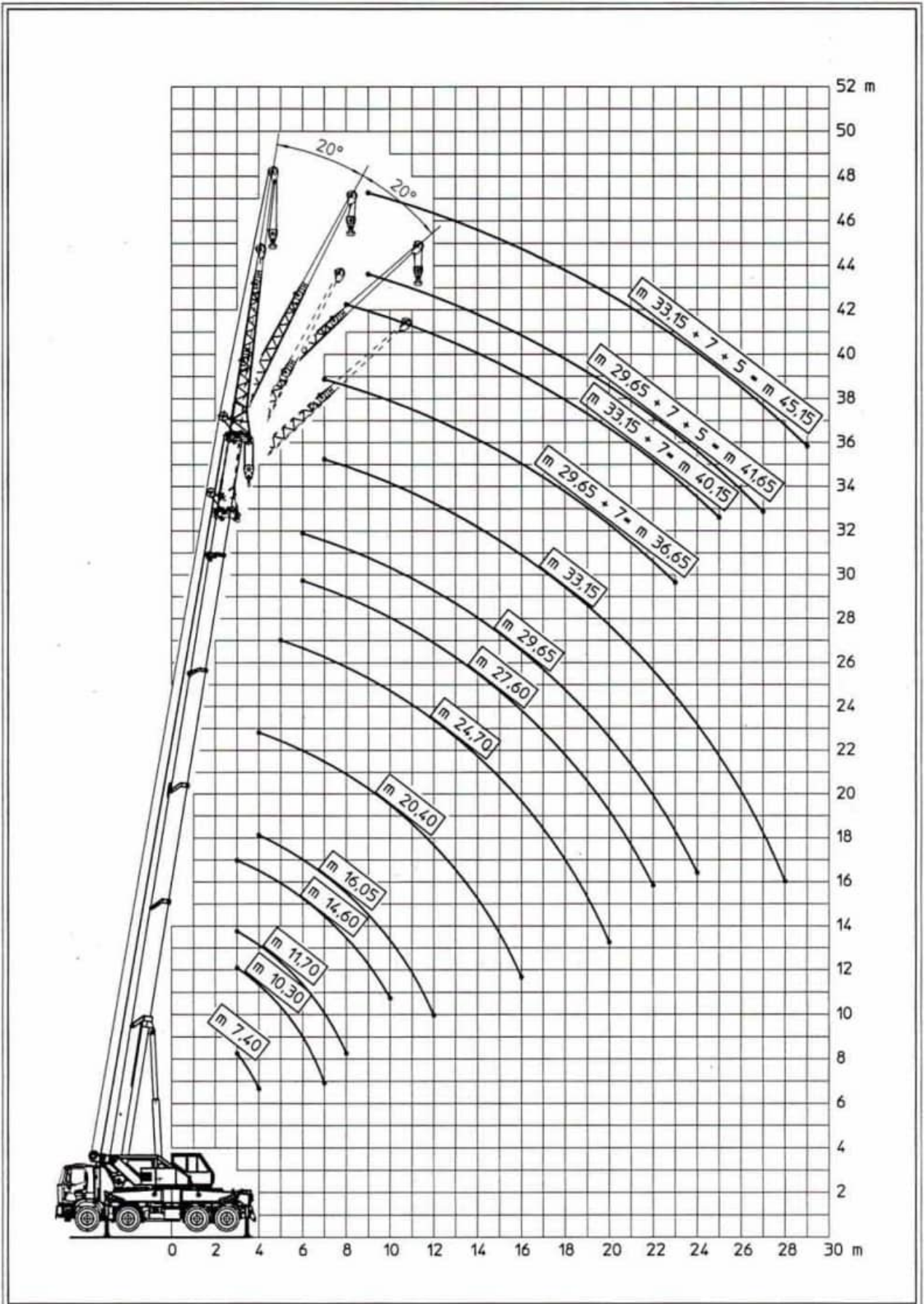

DIMENSIONI GENERALI - GENERAL DIMENSIONS
HAUPTABMESSUNGEN - DIMENSIONS GENERALES

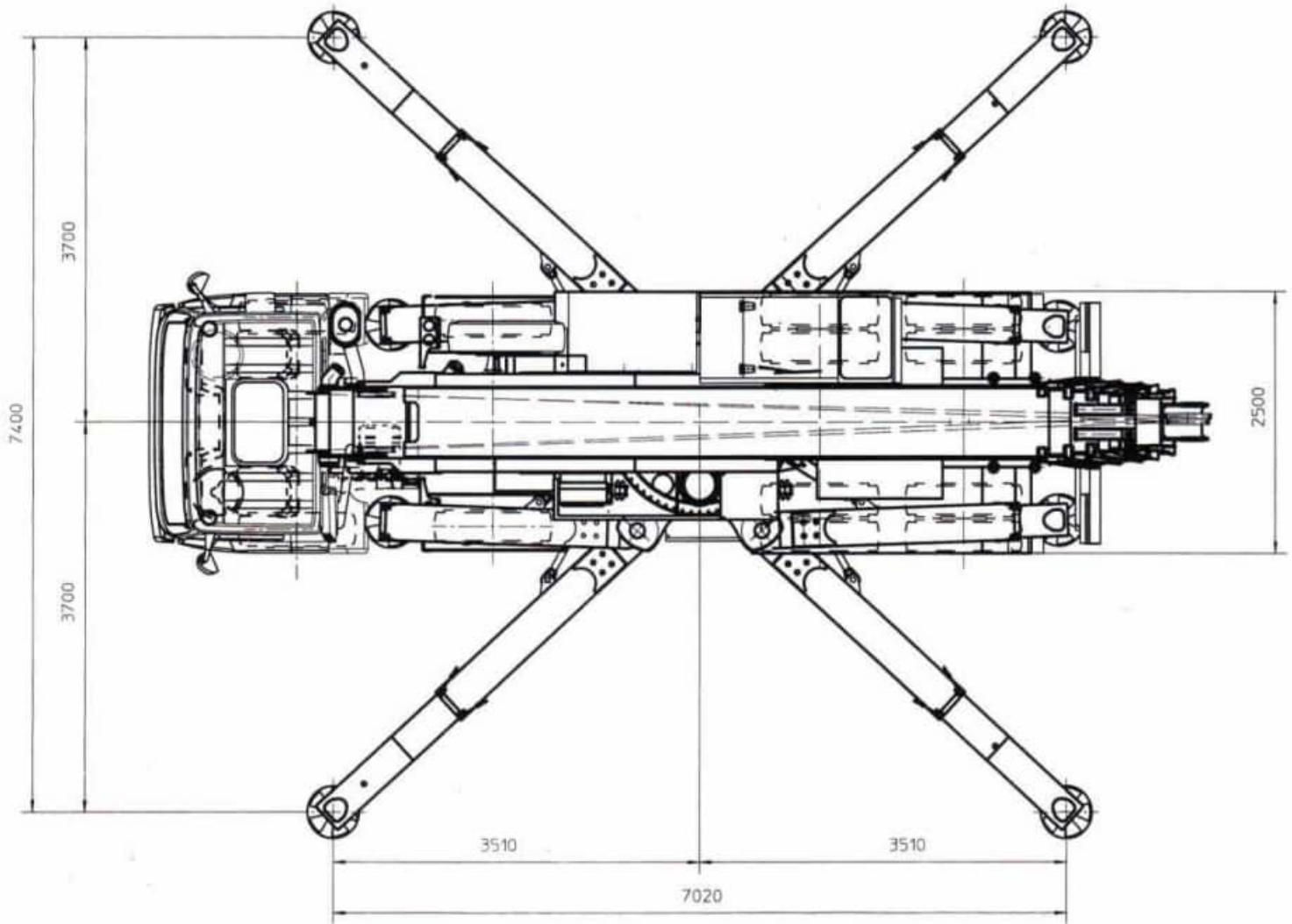
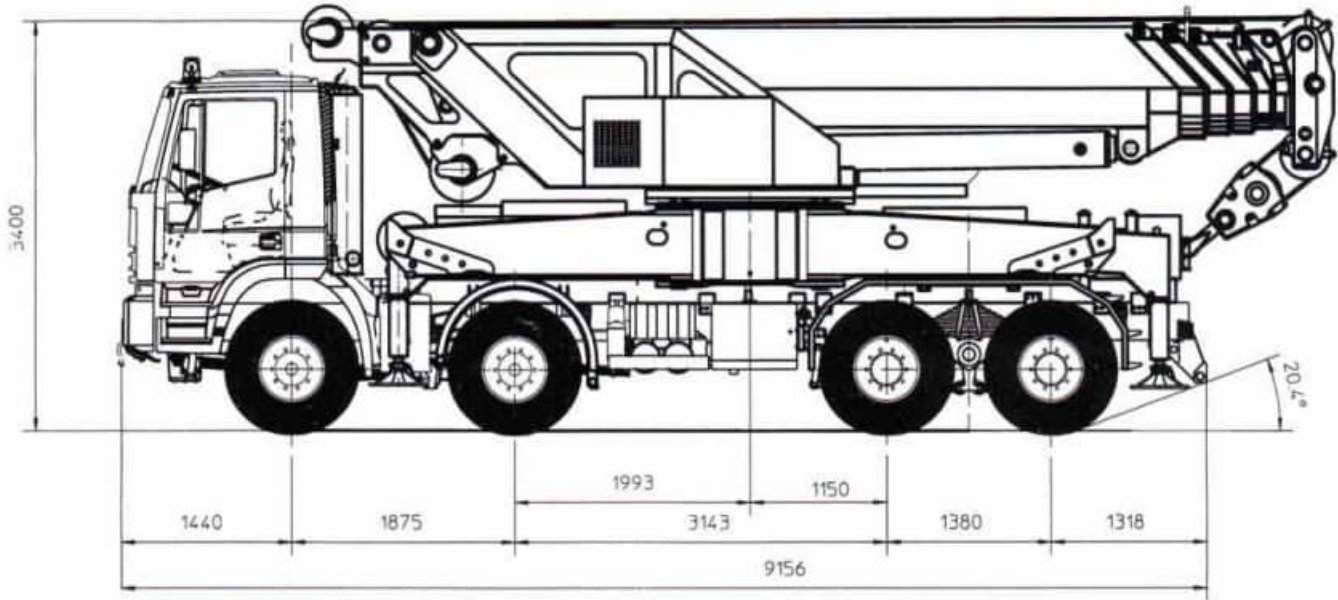

La ORMIG si riserva il diritto di apportare qualsiasi modifica senza preavviso né responsabilità.
ORMIG reserves the right to amend these specifications at any time without notice and responsibility.
ORMIG behält sich das Recht vor, jederzeit und ohne Vorankündigung Änderungen vorzunehmen.
ORMIG se réserve le droit d'apporter toute modification sans préavis né responsabilité.

autovictor

 *Keep on moving to the future.*

MANUALE TECNICO ORMIG 804 AC

AUTOVICTOR s.r.l.

Via Galvani 11/13

28060 San Pietro Mosezzo - Novara

Tel. +39 0321 35000

info@autovictor.it

www.autovictor.it